

Series 500/600 Mixers

TOP ENTRY MIXERS



A World Leader In Industrial Mixing Since 1923. Lightnin has over 85 years of unrivaled experience in industrial mixing technology, process knowledge, and technological innovation. Lightnin enjoys a global reputation for durable, long-lasting mixers, agitators, aerators, and flocculators for fluid process systems. We offer a full spectrum of impeller designs for diverse applications. In addition, we offer a worldwide service network, mixer repair, gearbox repair, and replacement parts programs. Look to Lightnin for knowledge, technology and service excellence.

Based in Charlotte, North Carolina, SPX Corporation (NYSE: SPW) is a global Fortune 500 multi-industry manufacturing leader. The company's highly-specialized, engineered products and technologies serve customers in three primary strategic growth markets: infrastructure, process solutions, and diagnostic systems. Many of SPX's innovative solutions are playing a role in helping to meet rising global demand, particularly in emerging markets, for electricity, processed foods and beverages and vehicle services. The company's products include thermal heat transfer equipment for power plants; power transformers for utility companies; process equipment for the food & beverage industry; and diagnostic tools and equipment for the vehicle service industry. For more information, please visit www.spx.com.

Series 500/600 Mixers - Designed for rugged, dependable service

The Lightnin Series 500/600 mixers offer the features and flexibility you want, so you'll never have to buy more mixer than you need. For basic mixing applications, standard Series 500/600 mixers provide rugged, dependable service without having to pay for options you don't want or won't use. For more complex applications, Series 500/600 mixers have a host of options to help you tackle the most difficult processes. You and your Lightnin sales engineer will simply select the impeller, motor, gear drive and seals that best meet your unique mixing needs.

SIMPLICITY

Series 500/600 mixers feature fewer parts, resulting in simpler maintenance than other mixers. The integral open-tank mounting base is bolted directly to the mounting surface without the need for a separate mounting plate. All mechanical seal options are interchangeable for easy upgrade, and the Series 600 S includes a shaft coupling that allows seal change without removing the gear drive. Seal options cover a wide range of pressure and temperature requirements for wet- and dry-running applications

EFFICIENCY

A wide selection of high-efficiency impeller types lets you pick the one that best fits your process. The robust rigid shaft connection means a larger effective upper shaft diameter for longer shaft length with no bottom steady bearing. Drive design accommodates English or Metric mixer shafts, mechanical seals and NEMA or IEC motors.

RELIABILITY

Time-tested, case-hardened gearing and all-ductile iron castings give Series 500/600 mixers unsurpassed strength and durability. Large bearings provide years of trouble-free service. An innovative dry-well design ensures no oil leakage even under the worst conditions. All Series 500/600 mixers are manufactured in Lightnin plants that are certified to ISO 9001 standards and come with Lightnin's 100% process guarantee.

VALUE

By selecting only the features you need for your unique process, Series 500/600 mixers deliver the best value for initial cost and total cost of ownership.

HIGH-EFFICIENCY IMPELLERS TO MATCH YOUR PROCESS NEEDS:



A310: General Purpose
New laser-designed impeller delivers true axial flow, high flow-per-horsepower, and can be custom-fit to your application.



A315: Gas-Liquids-Solids
Improves yield by up to 50% in shear-sensitive processes such as fermentation. The A315 is the optimum impeller for applications involving mass transfer and solids suspension.



A320: High-Viscosity
Fluid foil design reduces blend time by half and delivers better axial motion for 50% power saving compared to conventional pitch-blade turbines.

THEORY OF OPERATION:

Model 500-Q

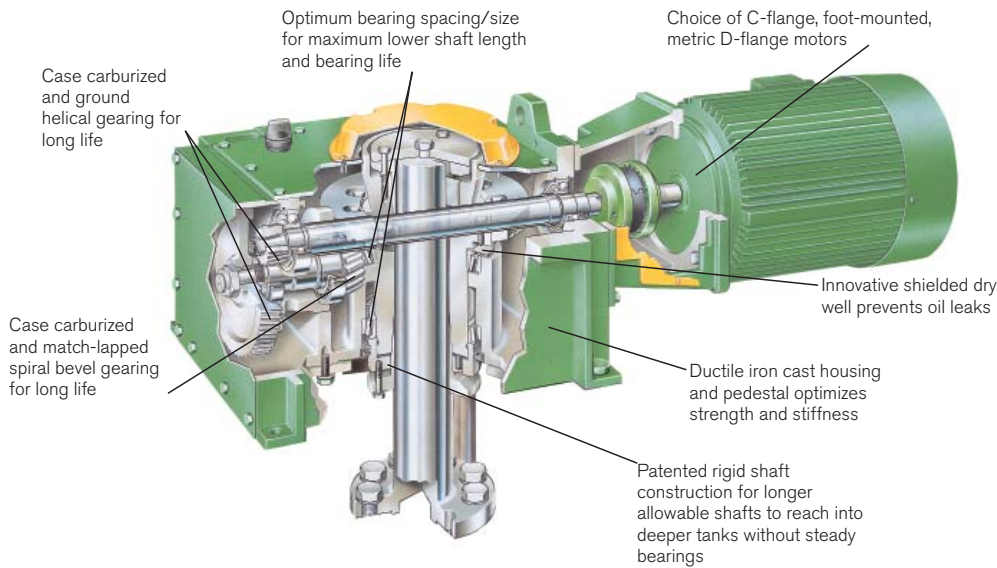

Model 600-S

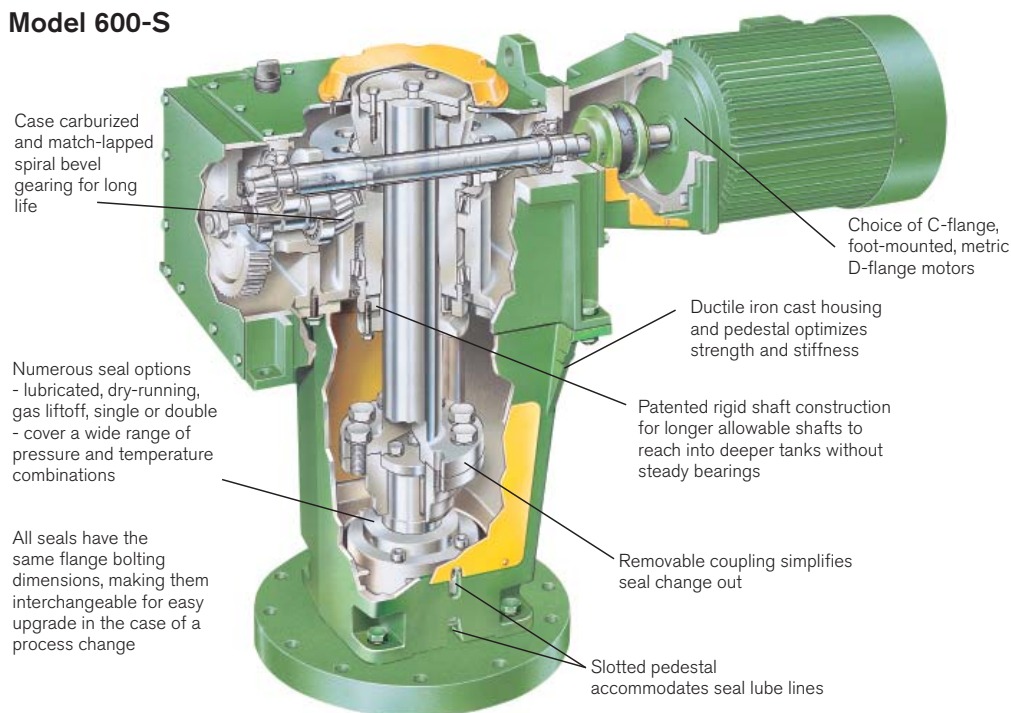

OPTIONS:

Series 500/600

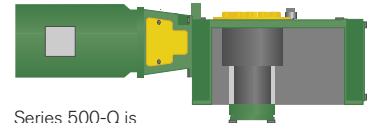

Series 500-Q is for open tank installations.

Series 500-C is a low profile stuffing box unit for low cost sealing of tank contents.

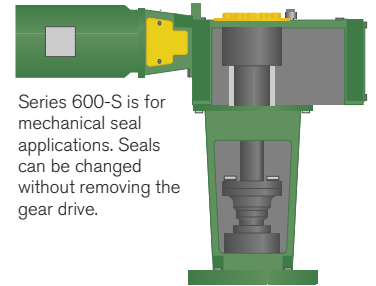

Series 600-S is for mechanical seal applications. Seals can be changed without removing the gear drive.

Model 500-Q

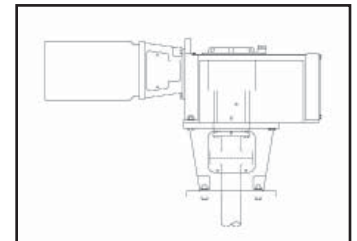

Model 500-C

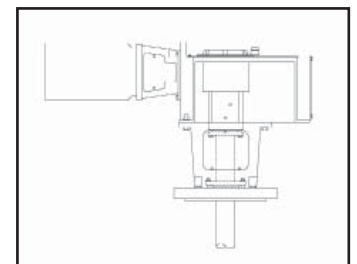

Model 600-S

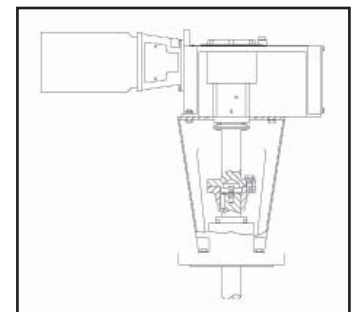

Series 500/600 Mixers

TOP ENTRY MIXERS



TECHNICAL SERVICES

The dedicated Lightnin brand after sales support teams are on hand to offer advice and support. With more than 85 years experience in the manufacture and supply of agitation equipment, we know what parts need to be on hand to support our customer base so that your downtime is minimized. Our team of highly experienced field service technicians is on call to support the on-site servicing of equipment, or supervise and train your maintenance staff in best practice care of equipment.

INSTALLATION AND COMMISSIONING

Proper installation of your Lightnin mixer is critical to its long term performance and reliability. To ensure that installation procedures

are followed, a certified technician will:

- Audit the equipment
- Supervise job-site contractors
- Perform a final inspection

SERVICE SUPPORT & REFURBISHMENT

The equipment audit is specifically designed to identify potential mechanical problems before they occur. Using many forms of modern technology and drawing on our mixer manufacturing experience, our technicians can identify the onset of bearing and gear failures, misalignment and system problems without the need to interrupt production. Factory gearbox exchange and refurbishment programs offer a fast and cost effective route to extending equipment life.

Global locations

USA

SPX GLOBAL HEADQUARTERS

13515 Ballantyne Corporate Place
Charlotte, NC 28277
United States of America
+1 704 752 4400

SPX FLOW TECHNOLOGY

135 Mt. Read Blvd.
Rochester, NY 14611
P: (888) 649-2378 (MIX-BEST), US and Canada) or +1 (585) 436-5550
F: (585) 436-5589
E: lightnin@spx.com ▪ www.lightninmixers.com

APAC

SPX ASIA PACIFIC

2F, Treasury Building
1568 Hua Shan Road
Shanghai 20000523
Peoples Republic of China
+86 21 2208 5888

EMEA

SPX EUROPE

Ocean House
Towers Business Park
Wilmslow Road
Manchester, M20 2LY England
+44 (0) 161 2491170

SPX reserves the right to incorporate our latest design and material changes without notice or obligation.

Design features, materials of construction and dimensional data, as described in this bulletin, are provided for your information only and should not be relied upon unless confirmed in writing. Please contact your local sales representative for product availability in your region. For more information visit www.spx.com.

The green ">" is a trademark of SPX Corporation, Inc.

ISSUED 03/2012 B-772

COPYRIGHT © 2012 SPX Corporation