

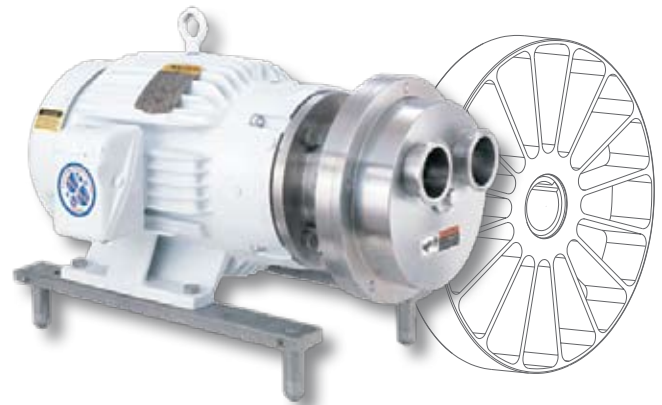

200LR Self-Priming Centrifugal Pumps

The 200LR Series Liquid Ring Pump handles products with entrained air as well as maintaining its prime when other pumps become air bound. This feature makes the 200LR the best choice for complete emptying of tanks and lines during normal process or CIP.

In addition to being an excellent CIP return pump, the 200LR can run in either direction, making it possible to fill or empty tanks with the same pump.



200LR Series Self-Priming Pump

Shown with Baldor washdown motor and optional S.S. leg kit.

The 200LR Series offers:

- Less overhead space needed due to both suction and discharge ports being on the front cover.
- Same seal(s) as used in 200 Series Centrifugal Pumps.
- Reduced noise levels.
- Stainless steel motor adapter is standard.
- JM Motor and no stub shaft eliminates need to check TIR (Total Indicated Run-out).

Features:

- All product contact surfaces are 316L stainless steel with 32Ra finish.
- Single or double mechanical seal available. (Size & materials same as WCB's 200 Series Centrifugal Pumps)
- Optional 25 or 20 Ra and/or electropolish product surfaces available.
- Optional 1" casing drain with 1" S-clamp connection available.
- Fluorocarbon elastomers standard. EPDM and silicone optional. All are FDA compliant per 21CFR177.2600.

Fluid End Cross Section

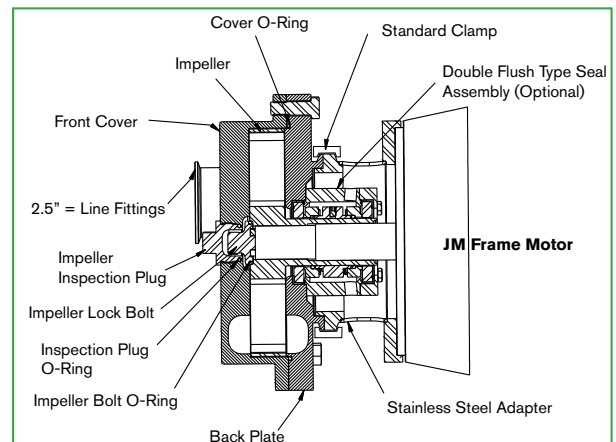

Common Applications:

- CIP Return
- Liquid Eggs
- Glycerin Transfer
- Yeast
- Cheese Whey
- Serum Whey
- Products With Viscosities up to 520 CPS

WCB 2065LR - Total Head and Horsepower vs Flow

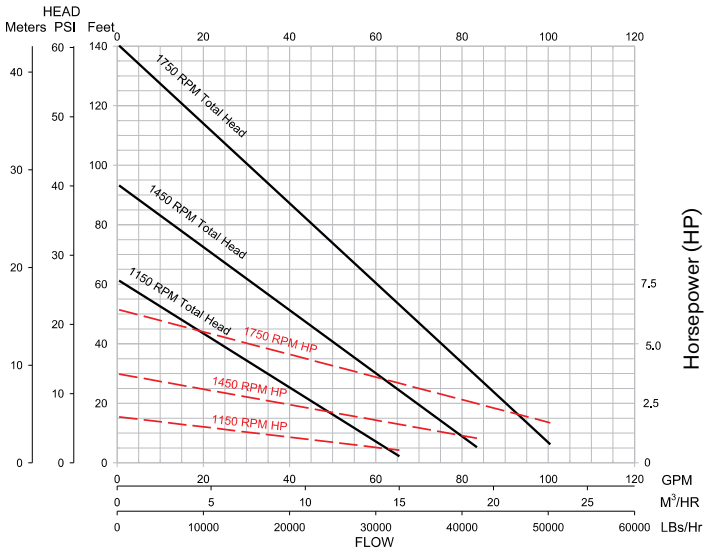

WCB 2085LR - Total Head and Horsepower vs Flow

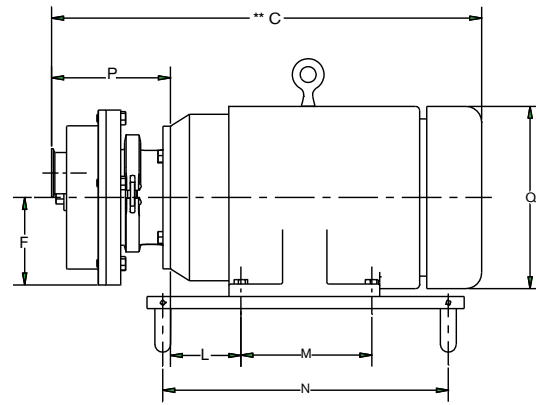
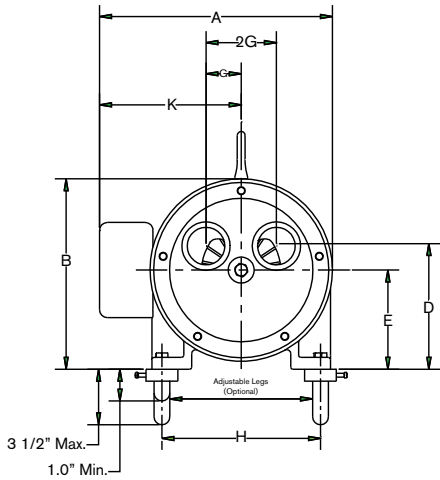
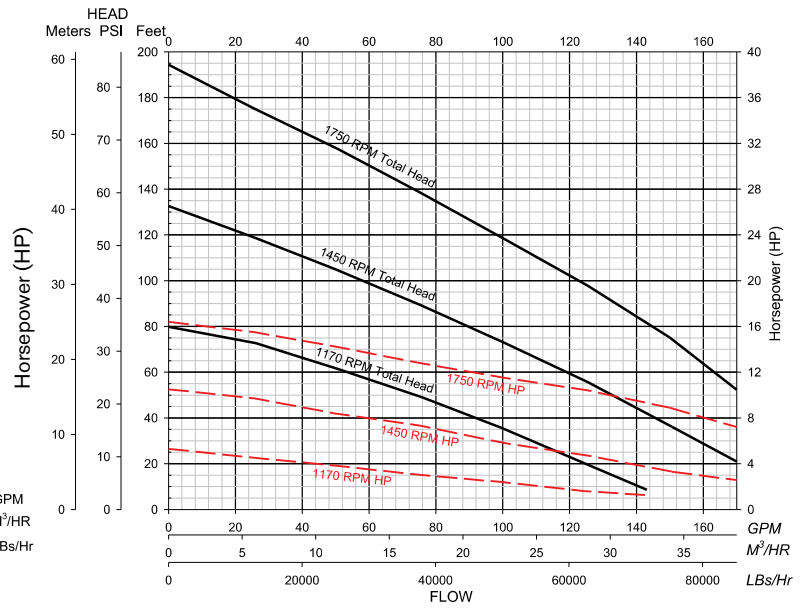

MODEL	INLET AND OUTLET SIZE INCHES (MM)	MOTOR HP	MOTOR FRAME	A INCHES (MM)	B INCHES (MM)	C INCHES (MM)	D INCHES (MM)	E INCHES (MM)	F INCHES (MM)	G INCHES (MM)	2G INCHES (MM)
2065LR	2.0 (51)	7.5/10	213/215 JM	13.44 (341)	10.34 (263)	23.51 (597)	6.51 (165)	5.25 (133)	4.56 (116)	1.88 (48)	3.76 (96)
2085LR	2.5 (64)	15/20	254/256 JM	14.9 (379)	12.0 (305)	27.4 (697)	7.75 (197)	6.25 (159)	5.50 (140)	2.25 (57)	4.50 (114)

MODEL	INLET AND OUTLET SIZE INCHES (MM)	MOTOR HP	MOTOR FRAME	H INCHES (MM)	K INCHES (MM)	L INCHES (MM)	M INCHES (MM)	N INCHES (MM)	P INCHES (MM)	Q INCHES (MM)	WEIGHT LBS (KG)
2065LR	2.0 (51)	7.5/10	213/215 JM	8.5 (216)	8.37 (213)	4.25 (108)	7.00 (178)/ 5.50 (140)	13.88 (353)	7.95 (202)	10.18 (259)	165 (75)
2085LR	2.5 (64)	15	254/256 JM	10.0 (254)	8.9 (227)	4.75 (120)	8.25 (209)/ 10.00 (254)	18.0 (457)	7.50 (191)	11.5 (292)	300 (136)/ 355 (161)

All motors are 1750 RPM

A.C.K.Q. Dimensions based on Baldor TEFC Motor, dimensions can vary depending on frame type and manufacturer.



SPX Process Equipment
 611 Sugar Creek Road
 Delavan, WI 53115
 Phone: (262) 728-1900 or (800) 252-5200 Fax: (262) 728-4904 or (800) 252-5012
 Email: wcb@spx.com
 For more information about our worldwide locations, approvals, certifications, and local representatives, please visit www.spxpe.com.
 SPX Corporation reserves the right to incorporate our latest design and material changes without notice or obligation. Design features, materials of construction and dimensional data, as described in this bulletin, are provided for your information only and should not be relied upon unless confirmed in writing.



PROCESS EQUIPMENT