

# Universal APU2 Pump Automotive Paint Series



# New levels of performance. Reduced paint shop and mix room costs.

For more than half a century, Waukesha Cherry-Burrell has been a leader in the design, manufacturing and application of external circumferential, piston (ECP) style, rotary positive displacement pumps. Waukesha Cherry-Burrell PD pumps are in thousands of challenging chemical and industrial applications. Universal APU2 Series are now in service in multiple plants, automotive and motorcycle manufacturers.

Users of Waukesha Cherry-Burrell PD pumps benefit from decades of continuing product improvement. Steady advances in design, metallurgy and fabrication techniques have yielded progressively higher levels of performance and service life.

The UNIVERSAL APU2 SERIES of pumps is the latest expression of this tradition. They combine 3-way mounting versatility with new features that extend pump life and improve performance.

## Features

- **316 stainless steel pump body and cover.**
- **Exclusive, non-galling Waukesha “88” alloy rotors standard;** permits running at tighter clearances and pumping a wide range of viscosities.
- **Silicone free.**
- **Rotor/shaft connection sealed** from product zone.
- **Mechanical seals standard.** Single or flushed double.
- **Up to 500 (34.5 bar) psi pressure capability.**
- **Rotor nut** designed for extended service without loosening.
- **No bearings in product zone.**
- **Larger diameter 17-4 PH shafts** in seal area for greater strength and stiffness. Helps eliminate vibration; extends seal life.
- **Heavy duty bearing frame.**
- **Double tapered roller bearings on all models.** Contribute further to precise rotor position and longer seal life.
- **Silicone free grease lubed bearings** for positive lubrication to all bearings over entire speed, temperature and pressure range.
- **Body retaining screws** for maintaining mechanical seal contact during inspection.
- **O-Ring on inner seal,** seals on clean surface as seal moves due to wear.
- **Bearing isolators** keep product out of gearcase and bearings.

## Installation Flexibility

- **Bi-directional flow.** Rotors, locked with unique washers and torqued nuts, rotate securely in either direction.
- **Interchangeable installation dimensions** with Universal 1 AP Series pumps.
- **Versatile 3-Way mounting** of gear case, including vertical alignment of ports.
- **Upper or lower drive shaft position.**



**Typical product applications**

- Water borne paints
- Solvent borne paints
- Clear coats
- Metallic flake paints
- Base coats

**Optional Coatings for Abrasive Applications**

- Armolloy® Coating*
- Composite Diamond Coating (CDC)*

## Benefits of Universal APU2 Series

- **Protects water-borne shear sensitive paints.**
- **Pigments are not separated**, which can change viscosity and cause color shifts.
- **Aluminum and mica metallic flakes are not damaged**, which result in deep rich paint luster, and shiny finish.
- **Color matching between body and components** is not a problem.
- **Substantial energy cost savings** compared to turbine and piston pumps.
- **Constant flow regardless of system pressure changes**, results in high film quality and thickness.
- **Pressure surges eliminated.**
- **Minimal heat added to product.**
- **Pumps are energy efficient**, and easily cleaned, maintained, and repaired.

Requirements	Waukesha	Turbine	Piston
Eliminates surge suppression	YES	YES	YES
Constant flow regardless of system pressure changes	YES	YES	YES
Minimal heat input	YES	NO	NO
Energy efficient	YES	NO	NO
Easily repaired	YES	NO	NO
Easily cleaned	YES	NO	NO
Easily maintained	YES	YES	NO
Prevent metallic flake degradation	YES	NO	YES

# Performance and long life through engineering.

**High pressure capability**, up to 500 psi/34.5 bar, for more demanding jobs.

**Metal rotor:** Waukesha "88" non-galling alloy, for close running clearance.

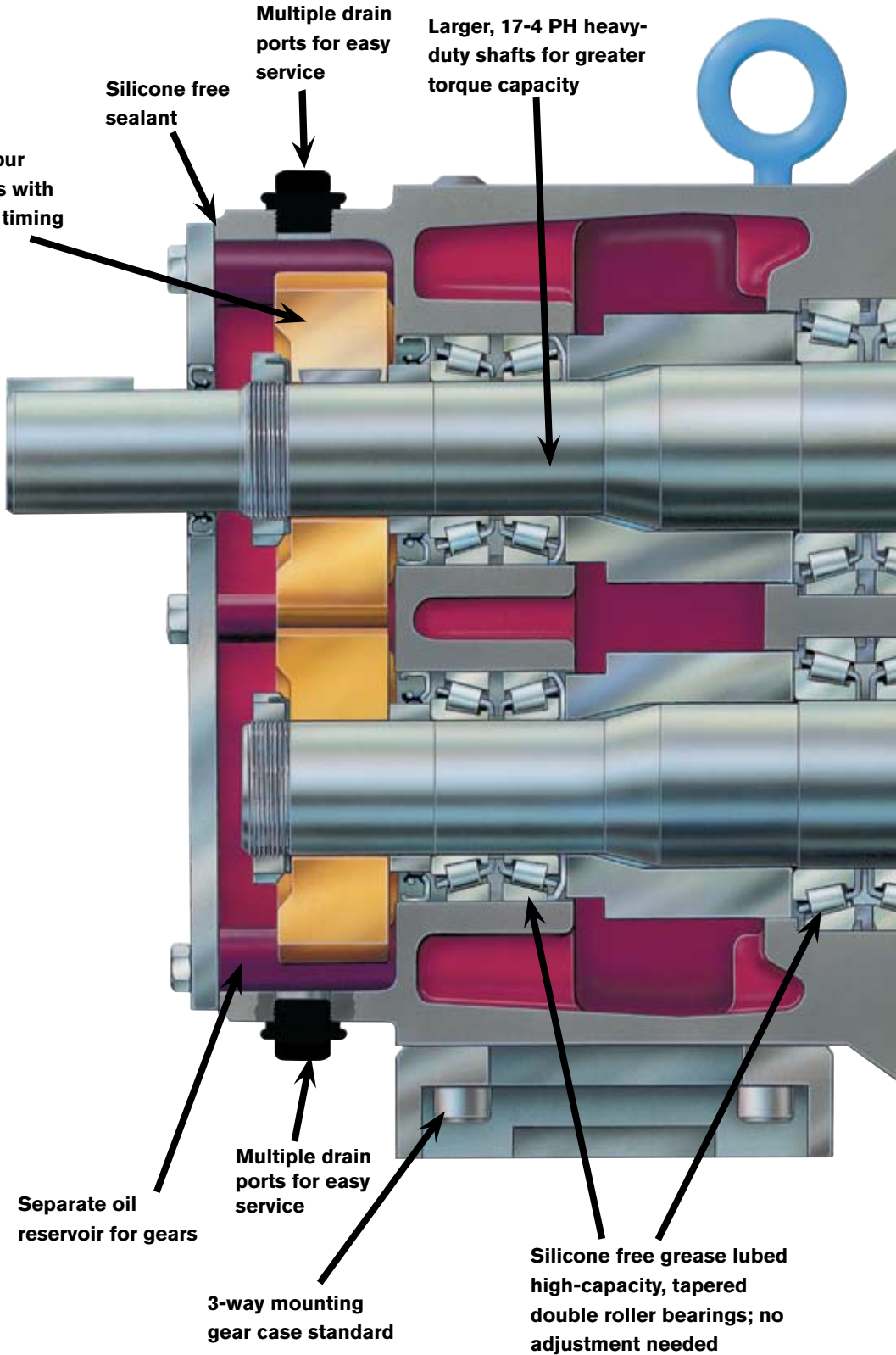

**Seal Options**

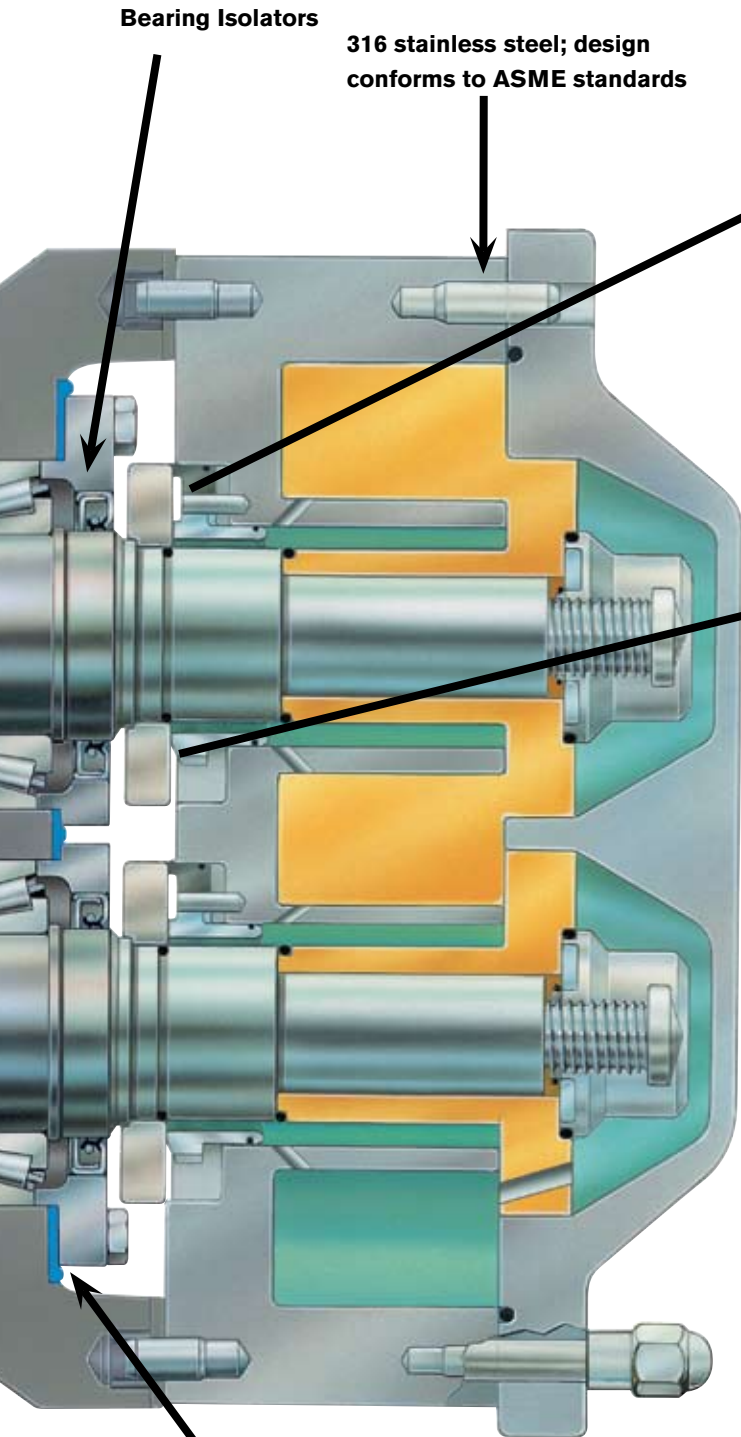

**Bearing Isolators**

**316 stainless steel; design conforms to ASME standards**

**Silicone free sealant**

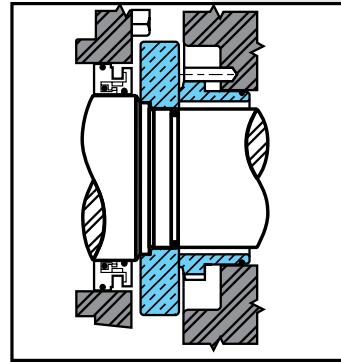

**Single Mechanical Seal\* (Standard)**  
Ceramic to ceramic faces.

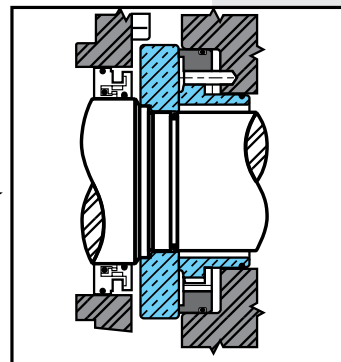

**Double Concentric Mechanical Seal\* (Optional)**  
Used with quench fluid to cool, lubricate, flush away residue. Best arrangement for difficult to seal paints and clear coats.

**Elastomers for "O" rings:**

- FFKM
- PTFE Encapsulated

**\*Mechanical seal material:**

**Single Seal:**

- Ceramic vs. Ceramic

**Double Seal:**

- Ceramic vs. Ceramic inner
- Ceramic vs. Carbon outer

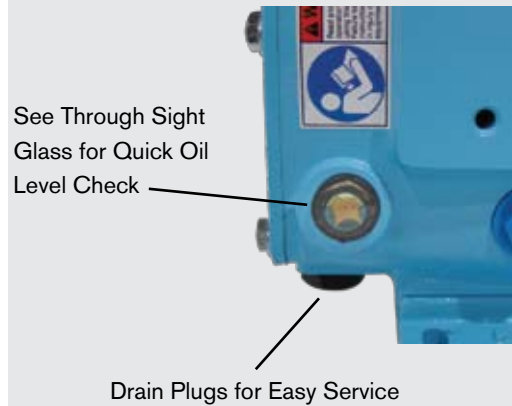

See Through Sight Glass for Quick Oil Level Check

Drain Plugs for Easy Service

# Specifications



Universal APU2 Pump

MODEL	DISPLACEMENT PER Revolution	Normal Capacity* To	Inlet/Outlet	Optional Inlet/Outlet	Pressure Range Up To	Maximum RPM*	Temp Range
AP 015-U2	0.0142 GAL. (0.054 LITER)	11 GPM (2.5 m <sup>3</sup> /hr.)	1 1/2"	-----	250 PSI (17.2 bar)	800	(-)40F °C to 300 °F (149 °C)
AP 018-U2	0.029 GAL. (0.110 LITER)	20 GPM (4.5 m <sup>3</sup> /hr.)	1 1/2"	2"	200 PSI (13.8 bar)	700	
AP 030-U2	0.060 GAL. (0.227 LITER)	36 GPM (8.2 m <sup>3</sup> /hr.)	1 1/2"	2"	250 PSI (17.2 bar)	600	
AP 040-U2	0.076 GAL. (0.228 LITER)	46 GPM (10.4 m <sup>3</sup> /hr.)	2"	-----	150 PSI (10.5 bar)	600	
AP 045-U2	0.098 GAL. (0.371 LITER)	58 GPM (13.2 m <sup>3</sup> /hr.)	2"	-----	450 PSI (31.0 bar)	600	
AP 060-U2	0.153 GAL. (0.579 LITER)	90 GPM (20.4 m <sup>3</sup> /hr.)	2 1/2"	3"	300 PSI (20.7 bar)	600	
AP 130-U2	0.253 GAL. (0.958 LITER)	150 GPM (34.1 m <sup>3</sup> /hr.)	3"	-----	200 PSI (13.8 bar)	600	
AP 180-U2	0.380 GAL. (1.438 LITER)	230 GPM (52.2 m <sup>3</sup> /hr.)	3"	-----	450 PSI (31.0 bar)	600	
AP 210-U2	0.502 GAL. (01.900 LITER)	300 GPM (68.1 m <sup>3</sup> /hr.)	4"	-----	500 PSI (34.5 bar)	600	
AP 220-U2	0.521 GAL. (0.1.972 LITER)	310 GPM (70.4 m <sup>3</sup> /hr.)	4"	-----	300 PSI (20.7 bar)	600	
AP 320-U2	0.752 GAL. (0.2.847 LITER)	450 GPM (102 m <sup>3</sup> /hr.)	6"	-----	300 PSI (20.7 bar)	600	

\* Listed capacity and maximum rpm for intermittent duty only.

Consult Waukesha Cherry-Burrell technical services for recommendations on your pumping requirements.

## Close coupled Tru-Fit™ pump mounted on Epoxy-painted open base.

### Features: ▪ No shaft alignment necessary. No coupling guard required.

- Special base design enhances cleanability.
- Reduces overall length of complete unit by an average of 20-25%.
- Average of 20-25 gear ratios available per horsepower.
- Separate oil sump for gear reducer and timing gears.

### Options: ▪ 304 SS unpolished plate base.

- 304 SS polished plate base.
- NEMA or IEC frames available. Right angle reducer also available for additional space savings.
- 1/2 through 60 horsepower drive options available.
- Horizontal or vertical porting.

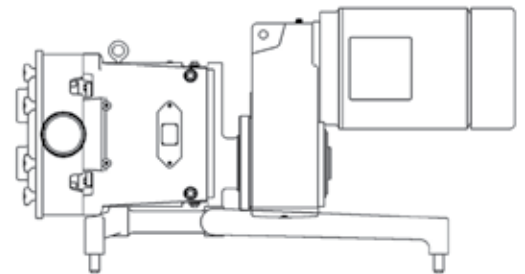

# Time-tested Waukesha Cherry-Burrell rotary pump; external circumferential piston (ECP) operating principle

In the Waukesha Cherry-Burrell design, arc-shaped “pistons” (rotor wings) travel in annular-shaped cylinders machined in the pump body; the resulting long sealing path reduces slippage and produces a smooth flow of product without destructive pulses or pressure peaks and without valves or complex parts.

## Exclusive Waukesha Cherry-Burrell design features

**For Low Viscosity Fluids**, rotors, made of exclusive Waukesha “88” alloy, can be run with close clearance to the 316 stainless steel fluid head, without galling or seizing should inadvertent pressure surges cause contact. The close clearances combined with the rotor geometry, which gives a long sealing path between the pump inlet and outlet, means low slip operation. As a result, you achieve: high volumetric efficiency and good flow control.

**For High Viscosity Fluids**, the large fluid cavities of the rotors ... plus the large, easy entry anti-cavitation ports ... allow efficient pumping of high viscosity fluids, slurries or even liquids with large chunks or particles.

**For Non-Lubricating and Abrasive Fluids**, the unique Waukesha Cherry-Burrell design has no bearings in the fluid being pumped, no sliding or rolling contact and no rotor-to-rotor contact. This produces **MAXIMUM SERVICE LIFE** even under severe operating conditions.

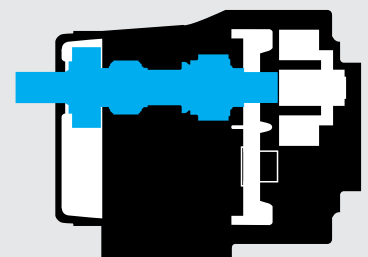
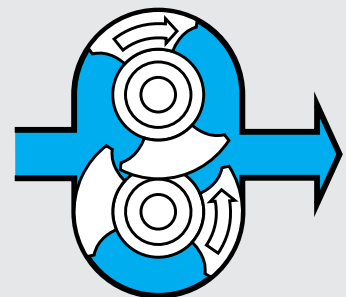
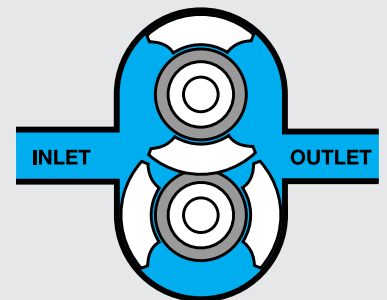
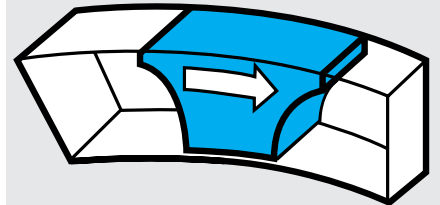

# Dimensions

Pump Model		CP	I	L	O	Port Size	U +.000 -.001	2X
AP 015-U2	IN	11.71	7.66	9.61	4.21	1-1/2"	.875	6.97
	MM	297	194	244	107	-----	22.23	177
AP 018-U2	IN	12.37	7.66	10.48	4.21	1-1/2"	.875	6.97
	MM	314	194	266	107	-----	22.23	177
AP 030-U2	IN	14.49	8.83	11.61	5.21	1-1/2"	1.250	8.50
	MM	368	224	295	132	-----	31.75	216
AP 040-U2	IN	14.87	8.83	11.77	5.21	2"	1.25	8.62
	MM	378	224	305	132	-----	31.75	219
AP 045-U2	IN	18.59	10.99	14.86	7.31	2"	1.625	10.75
	MM	472	279	377	186	-----	41.28	273
AP 060-U2	IN	19.14	10.99	15.14	7.31	2-1/2"	1.625	10.75
	MM	486	279	385	186	-----	41.28	273
AP 130-U2	IN	20.15	10.99	15.77	7.31	3"	1.625	10.75
	MM	512	279	401	186	-----	41.28	273
AP 180-U2	IN	23.26	14.80	18.25	9.38	3"	2.000	13.06
	MM	591	376	464	238	-----	50.80	332
AP 210-U2	IN	27.08	17.80	21.24	10.38	4"	2.375	14.73
	MM	688	452	539	264	-----	60.45	374
AP 220-U2	IN	24.00	14.80	18.49	9.38	4"	2.000	13.25
	MM	610	376	470	238	-----	50.80	337
AP 320-U2	IN	27.66	17.80	21.63	10.38	6 150# FLG	2.375	16.000
	MM	703	452	549	264	-----	60.45	406

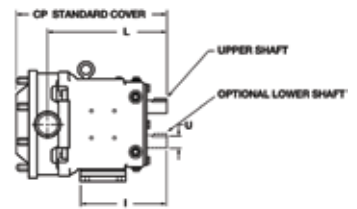
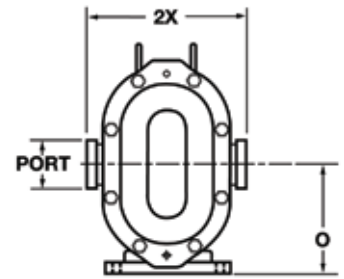

NOTE: Dimension "2X" applies for "S"-Clamp on Models 015 through 220.

DIN and other connections available.

Dimension "2X" applies for 6" 150 lb. RF Flange on Model 320.



# SPX®

## PROCESS EQUIPMENT

Your local contact:



SPX Process Equipment

611 Sugar Creek Road

Delavan, WI 53115

Phone: (262)728-1900 or (800)252-5200 Fax: (262)728-4904 or (800)252-5012

E-mail: [wcb@spx.com](mailto:wcb@spx.com)

For more information about our worldwide locations, approvals, certifications, and local representatives, please visit [www.spxpe.com](http://www.spxpe.com).

SPX Corporation reserves the right to incorporate our latest design and material changes without notice or obligation.

Design features, materials of construction and dimensional data, as described in this bulletin, are provided for your information only and should not be relied upon unless confirmed in writing.

Issued: 01/2009 FH-1737

Copyright © 2002, 2008 SPX Corporation