

Rotary Positive Displacement Pumps Universal Lobe Series



High Volume, Lower Cost, CIP

For more than half a century, Waukesha Cherry-Burrell has been a leader in the design, manufacturing and application of external circumferential piston, positive displacement pumps. Waukesha PD pumps are in service around the world in food, dairy, canning, bakery, beverage and pharmaceutical processing, as well as challenging chemical and industrial applications.

Users of Waukesha PDs benefit from decades of continuing product improvement. Steady advances in design, metallurgy and fabrication techniques have yielded progressively higher levels of performance and service life. Most of the pumps that have carried the Waukesha Cherry-Burrell name over this time were designed for heavy-duty pumping challenges.

The new Universal Lobe Pumps were specifically designed for a different challenge: lower cost and CIP (clean in place) applications.

While intended for lower cost, Universal Lobe Pumps are not “light duty.” They incorporate the advanced technology of the new Universal II PD that strengthens sanitary performance and extends pump life. They are capable of accommodating high temperatures and pressures up to 300 psi.

Universal Lobe Pump Series utilize the Universal II gear case with 3-way mounting flexibility. It offers the full range of seal and port options and has Integral Speed Reducer (ISR) mounting capabilities.



The Universal Lobe Pump from Waukesha Cherry-Burrell

Sanitation Features

- CIPable. Pump body has an internal flat profile and is free draining with vertical ports.
- Cover is free draining in horizontal or vertical port positions.
- Rotor/shaft connection sealed from product zone.
- Exclusive, non-galling Waukesha “88” alloy rotors standard; permits running at tighter clearances and higher efficiencies; 316 stainless steel lobe rotors also available.
- Mechanical seals standard. Single or flushed double.
- Seal flush optional: seal areas interconnected to improve circulation and draining of seal flush fluid. Steam-In-Place also is optional.
- Jacketed cover optional.
- 316 stainless steel pump body and cover; 316L optional.
- Electro-polish of product contact surfaces, optional.
- Stainless steel bearing frame optional.



Shown with optional stainless steel gearcase

Long-life features

Precision rotor movement virtually eliminates vibration; extends seal life.

- Rotor nut designed for extended service without loosening.
- No bearing in product zone.
- Larger diameter shafts in seal area for greater strength and stiffness.
- Heavy duty bearing frame (stainless steel available as an option)
- Double tapered roller bearings on all models. Contribute further to precise rotor movement and longer seal life.
- Greased lubed bearings for positive lubrication to all bearings over entire speed, temperature and pressure range.
- Body retaining screws for maintaining mechanical seal contact during inspection.
- Extended outer seal life. A wave spring, instead of an O-ring, mechanically loads the seal.
- O-Ring on inner seal, seals on clean surface as seal moves due to wear.
- 3 full-radius drive pin grooves reduce stress/increase durability of seals.

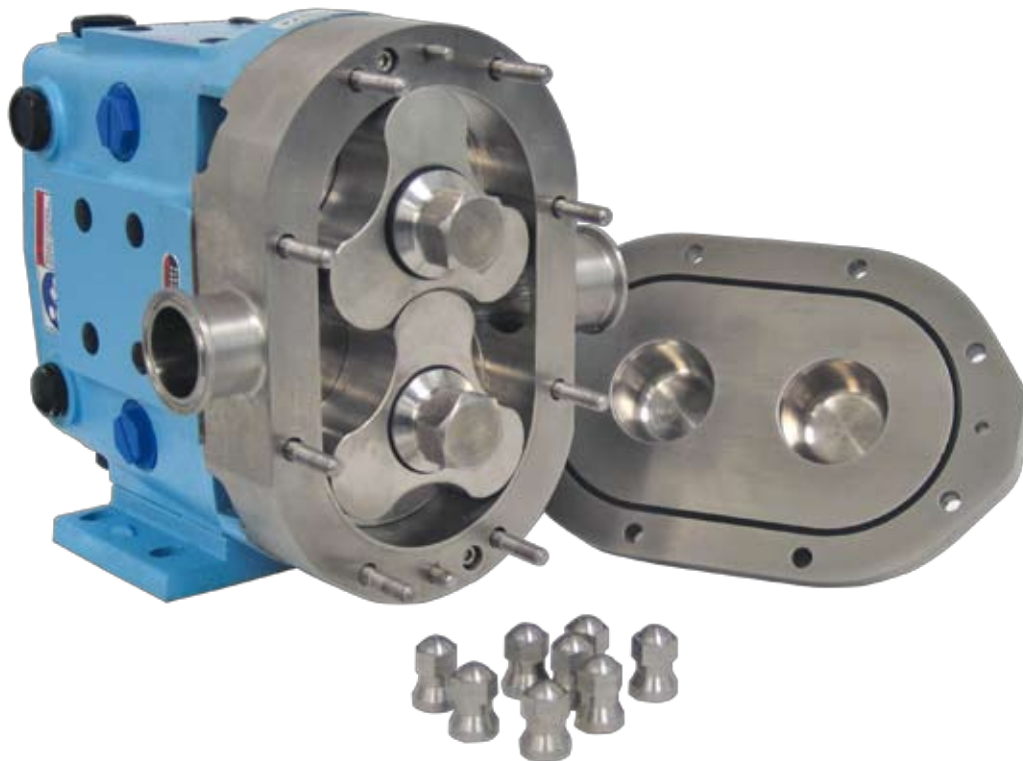

Installation flexibility

- Bidirectional flow. Rotors, locked with belleville washers and torqued nuts, rotate securely in either direction. No more flow direction/shaft position specification.
- Interchangeable installation dimensions with Universal and Universal II PD pumps.
- Versatile 3-Way mounting of gear case, including vertical alignment of ports.
- Upper or lower shaft position.



Specifications

MODEL	DISPLACEMENT PER REVOLUTION	NORMAL CAPACITY TO*	INLET/OUTLET	PRESSURE RANGE UP TO**	MAXIMUM RPM	TEMP. RANGE**
018-UL	.033 GAL. (.12 LITER)	33 GPM (7.5 m ³ /hr.)	1 1/2"	200 PSI (13.8 bar)	1000	-40° F/C to 300° F (149° C)
030-UL	.071 GAL. (.27 LITER)	70 GPM (15.9 m ³ /hr.)	1 1/2"	300 PSI (20.7 bar)	1000	
060-UL	.153 GAL. (.58 LITER)	120 GPM (27.2 m ³ /hr.)	2 1/2"	300 PSI (20.7 bar)	800	
130-UL	.253 GAL. (.96 LITER)	175 GPM (39.7 m ³ /hr.)	3"	200 PSI (13.8 bar)	700	
220-UL	.502 GAL. (1.90 LITER)	300 GPM (68.1 m ³ /hr.)	4"	200 PSI (13.8 bar)	600	
320-UL	.878 GAL. (3.32 LITER)	525 GPM (119.2 m ³ /hr.)	6"	200 PSI (13.8 bar)	600	

**Contact application engineering for higher pressure and temperature applications.

Typical product applications

Bakery

Batters
Flavorings Frostings
Fats & Oils Sweeteners
Yeast
Slurry

Beverage

Beer, Wort, Yeast Soft Drinks
Fruit Drinks
Juice Concentrate

Canning

Baby Foods,
Soups
Fruit Puree
Puddings,
Jellies
Salad Dressings,
Mayonnaise

Confectionary

Syrups
Cream Fillings
Chocolate

Cosmetics

Face Creams & Lotions
Hair Styling Gels
Liquids Essential Oils
Dyes & Alcohols

Dairy

Cream
Milk Ice Cream Mix
Yogurt

Chemical/Industrial

Solvents
Fuels
Oils & Lubricants
Soaps

Performance and Long Life Through Engineering.

Higher pressure capability, up to 300 psi/20.7 bar.

Longer service life resulting from fresh engineering approach and high capacity components.

The right seal for every application, plus interchangeability when needed.

Metal rotor: exclusive Waukesha 88 non-galling alloy rotors provide close clearance; 316 stainless lobe rotors available.

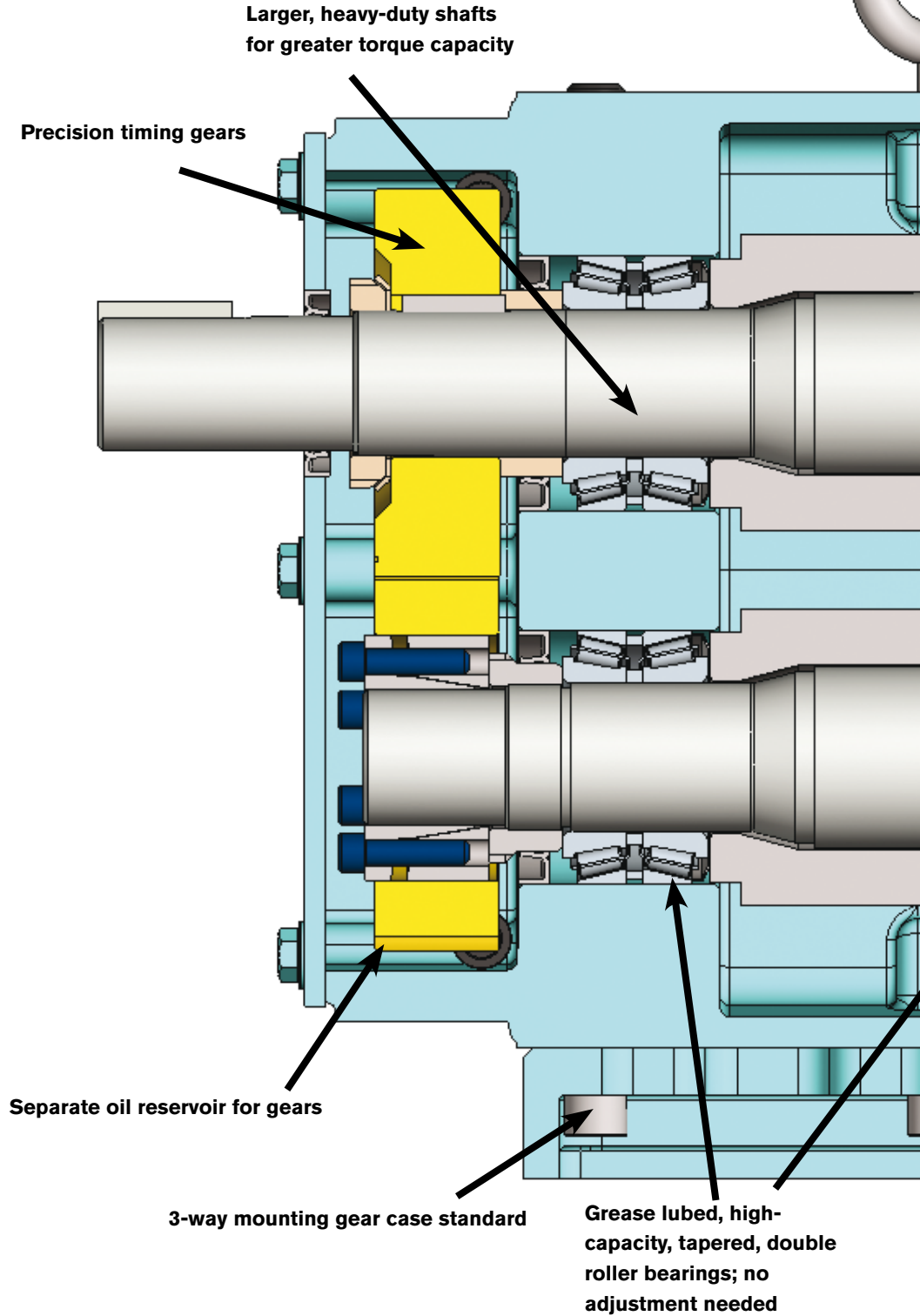

Seal Options

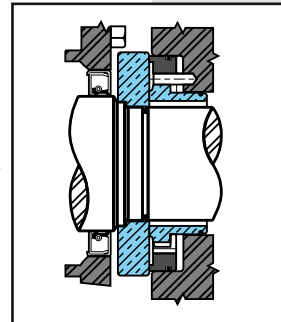
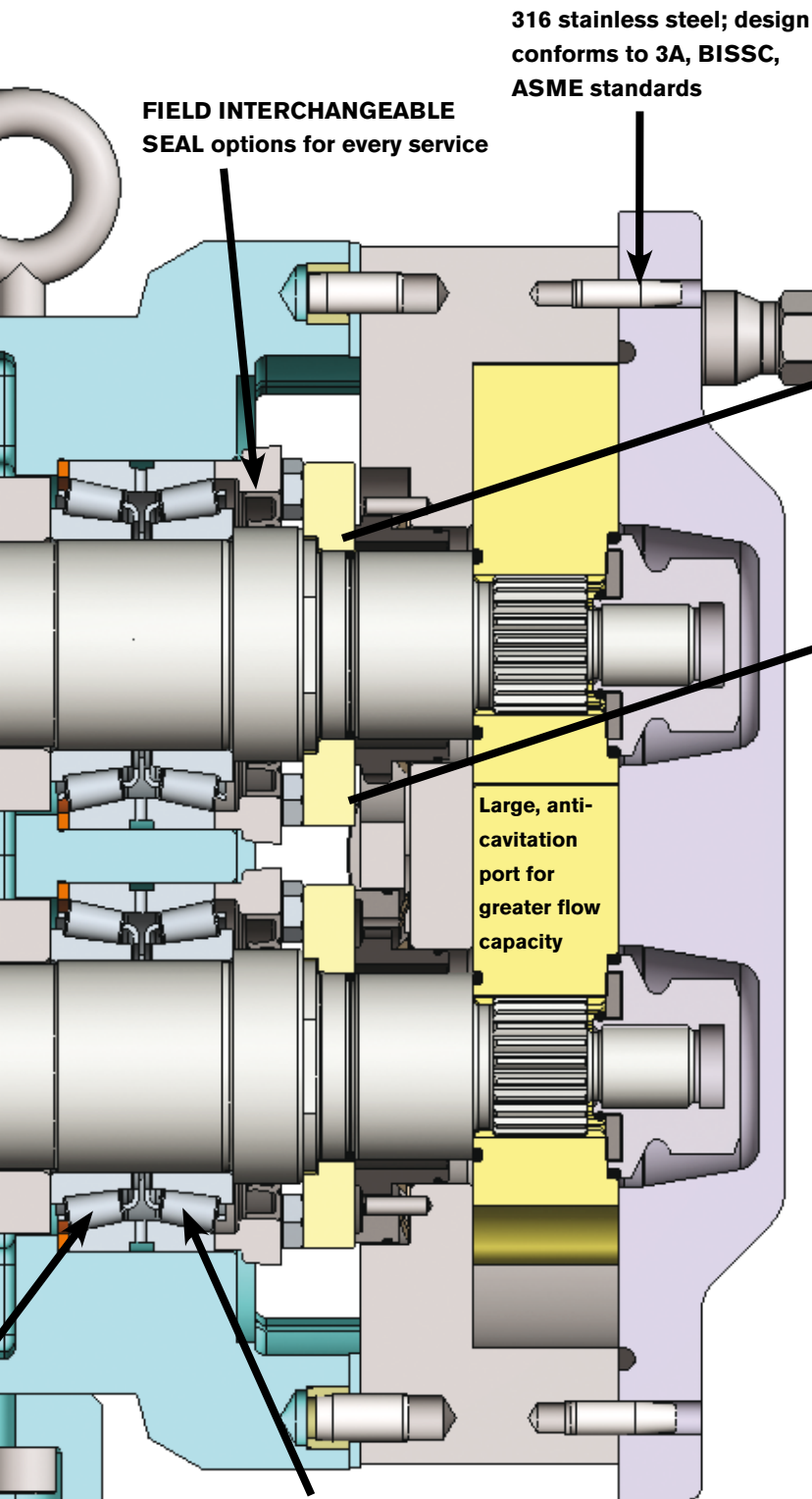

Double Concentric Mechanical Seal*

Used with flushing fluid to cool, lubricate, flush away residue. Best arrangement for severe service.

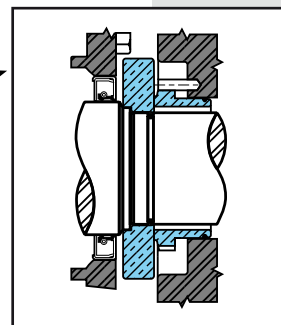

Single Mechanical Seal*

Longer life, wider pressure-temperature-speed range. Carbo-to-ceramic faces standard. Alternate materials available for abrasive service.

Elastomer choices for "O" rings:

- Buna-N
- Fluoroelastomer (FKM)
- EPDM
- Silicone
- Perfluoroelastomer (FFKM)
- PTFE Encapsulated

***Mechanical seal material options:**

- Carbon
- Ceramic
- Silicon Carbide
- Tungsten Carbide

Standards & Options

Ports

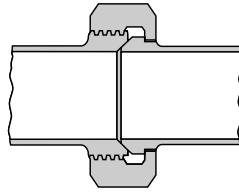

**Bevel Seat
Standard**

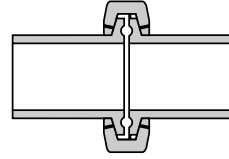

**Optional Sanitary Clamp
Type Variety of styles
including S-Line, I-Line,
Q-Line**

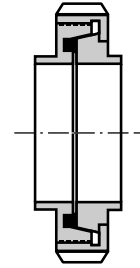

**Optional
European Types;
DIN, SMS, RJT**

Male NPT and 150 lb. flanges optional on Models 018 through 220 size.
150 lb. RF flanges standard on Model 320.

Rotors

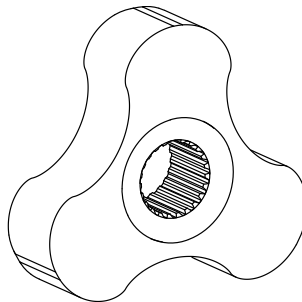

**Alloy 88 Standard.
316SS Optional.**

Rotor clearance standard for most applications up to 200° F.
Hot clearance rotor option for applications up to 300° F.
Contact application engineering for higher temperature applications.

O-Rings

Elastomer choices for "O" rings:

- | Standard | Optional |
|-----------------|----------------------------|
| ▪ Buna-N | ▪ Viton |
| | ▪ EPDM |
| | ▪ Silicone |
| | ▪ Kalrez/PTFE Encapsulates |

Cover & Gearcase

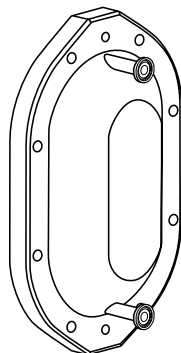

*Optional drain and/or
vent connections*



*Shown with optional
3-wing cover nuts*

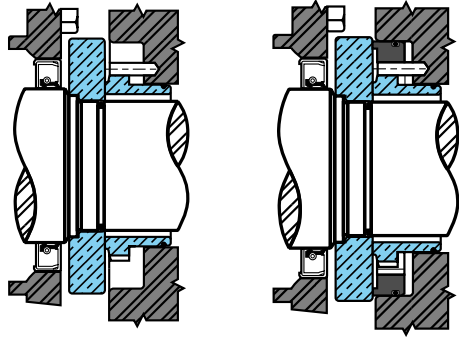

Single Mechanical Seal

Double Concentric Mechanical Seal

Mechanical seal material options:

- Carbon
- Ceramic
- Silicon Carbide
- Tungsten Carbide

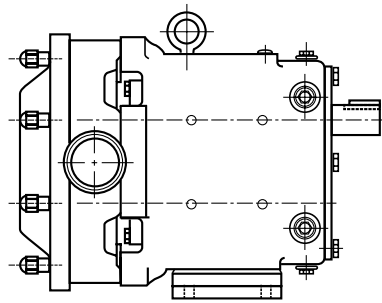

Top Shaft Position Standard

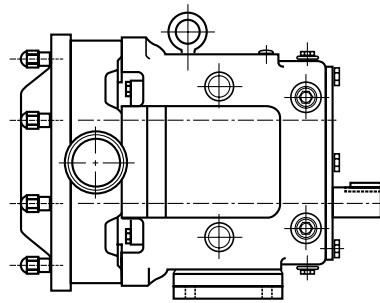

Lower Shaft Position Optional

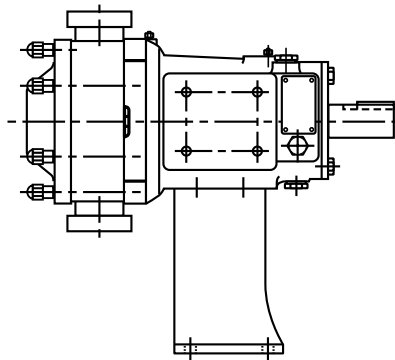

Optional Side Mount Gear Case for vertical fluid entry and free draining of body

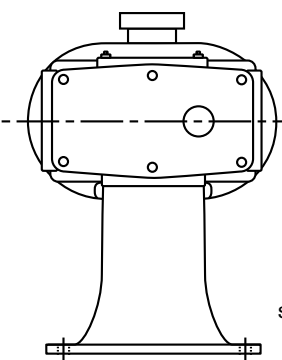

Standard left hand shaft position shown (right hand optional)

- Plate with adjustable feet or Channel Bases
- 304 SS Plate Bases
- Portable Bases with Rubber Wheels
- Direct connected Gear Motors
- Mechanical and Electronic Variable Speed Drives
- Hydraulic Motor Drives

Seals

Shaft Position

Mounting

Bases & Drives

Dimensions

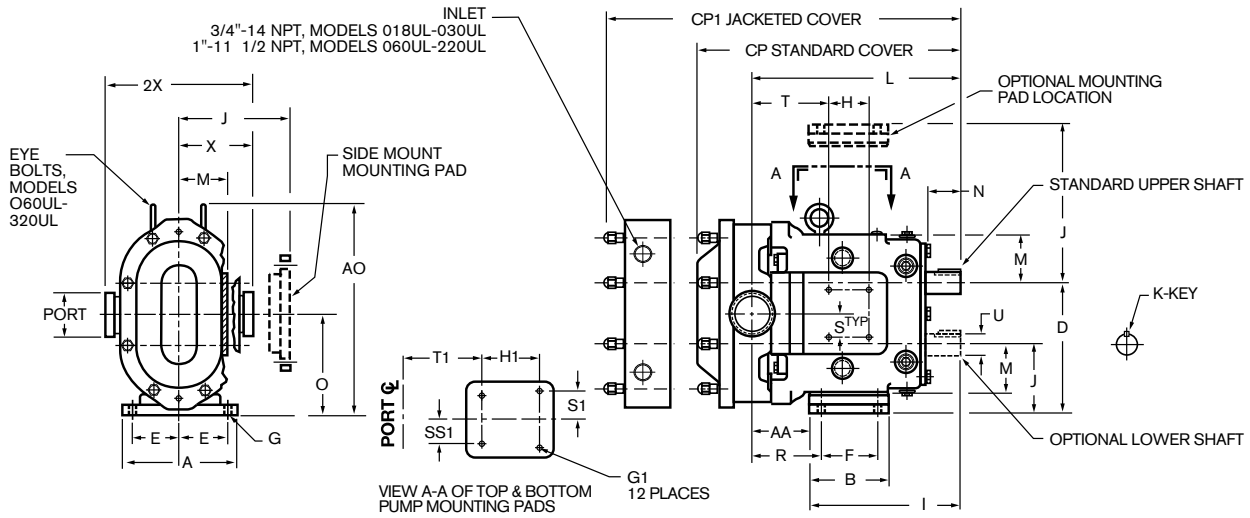

		A	AA	AO	B	CP	CP1*	D	E	F	G	G1	H	H1	I	J
018-UL	IN	4.75	2.82	8.30	3.75	12.37	14.53	5.50	1.94	2.31	.41, SLOT	5/16-18 x .62	2.50	2.50	7.66	293
	mm	121	72	211	95	314	369	140	49	59	10, SLOT	-	64	64	194	74
030-UL	IN	6.25	2.78	10.29	4.25	14.49	16.43	6.86	2.31	2.56	.41, SLOT	3/8-16 x .62	1.81	2.75	8.83	356
	mm	159	71	261	108	368	417	174	59	65	10, SLOT	-	46	70	224	90
060-UL	IN	8.25	4.14	15.31	5.87	18.26	21.00	9.56	3.50	4.12	.53	1-2-13 x .88	3.00	4.13	10.99	506
	mm	210	105	389	149	464	533	243	89	105	.13	-	76	105	279	129
130-UL	IN	8.25	4.78	15.31	5.87	19.28	22.02	9.56	3.50	4.12	.53	1/2-13x.88	3.00	4.13	10.99	506
	mm	210	121	389	149	490	559	243	89	105	13	-	76	105	279	129
220-UL	IN	8.50	3.69	19.13	9.00	23.07	25.81	12.38	3.75	7.25	.53, SLOT	1/2-13x1.00	5.38	5.38	14.80	638
	mm	216	94	486	229	586	655	314	95	184	13, SLOT	-	137	137	376	162
320-UL	IN	12.00	4.12	22.38	11.63	26.65	NA	13.88	5.25	8.00	.66	1/2-13x1.00	5.38	5.38	17.80	688
	mm	305	105	568	295	677	NA	353	133	203	17	-	137	137	452	175

		K	L	M	N	O	PORT	R	S	S1	SS1	T	T1	U +.000 -.001	X**	2X**
018-UL	IN	.19	10.48	2.12	2.00	4.21	1-1/2"	3.66	1.00	1.00	1.00	3.38	2.51	.875	3.49	6.97
	mm	5	266	54	51	107	-	93	25	25	25	86	64	22.23	89	177
030-UL	IN	.25	11.61	2.62	2.32	5.21	1-1/2"	3.84	1.12	1.12	1.12	4.00	3.59	1.250	4.25	8.50
	mm	6	295	67	59	132	-	98	28	28	28	102	91	31.75	108	216
060-UL	IN	.38	15.14	3.50	2.25	7.31	2-1/2"	5.01	1.75	2.00	1.75	5.62	5.01	1.625	5.37	10.75
	mm	10	385	89	57	186	-	127	44	51	44	143	127	41.28	136	273
130-UL	IN	.38	15.77	3.50	2.25	7.31	3"	5.65	1.75	2.00	1.75	6.25	5.66	1.625	5.37	10.75
	mm	10	401	89	57	186	-	144	44	51	44	159	144	41.28	136	273
220-UL	IN	.50	18.49	4.50	2.75	9.38	4"	4.44	2.69	2.69	2.69	6.00	6.00	2.000	6.63	13.25
	mm	13	470	114	70	238	-	113	68	68	68	152	152	50.80	168	337
320-UL	IN	.63	21.65	5.06	4.06	10.38	6" 150# FLANGE	5.09	2.69	2.69	2.69	8.37	8.37	2.375	8.00	16.00
	mm	16	550	129	103	264	-	129	68	68	68	213	213	60.45	203	406

*NOTE: CP1 will not apply to Model 320.

**NOTE: Dimensions "X" and "2X" apply for Bevel Seat, "S"-Clamp, "Q"-Clamp, 151 and 141 fittings on Models 018 through 220. Standard port is Bevel Seat.

Dimensions "X" and "2X" apply for 6" 150 lb. RF Flange on Model 320.

Engineering

Research, design and application engineers at Waukesha Cherry-Burrell possess extensive backgrounds in their respective fields. You can draw on this experience to solve pumping problems or to counsel on process systems design. The imagination and resourcefulness of our engineers have often helped improve our customers' profits through production efficiencies.



Testing

Ideas do not remain abstract long at Waukesha Cherry-Burrell. Application of our products to our customer's specific needs often requires practical testing using real-world parameters. We have a fully equipped and staffed facility for this purpose. For example, the Rheology Laboratory tests applications involving highly viscous fluids.



Sales & Service Network

Waukesha Cherry-Burrell's trained sales and application engineers are always available for personal consultation to help solve any installation or operational problem. A large number of fully trained Waukesha Cherry-Burrell stocking distributors throughout the country and around the world provide quality Waukesha Cherry-Burrell replacement parts and service.

Quality Control

To maintain the product line's reputation for quality and to assure that every unit is shipped "ready to install," each Waukesha pump is thoroughly inspected at every stage of manufacturing and assembly and then tested for design specification. Following the tests, it is disassembled and reinspected before shipment. **Waukesha Cherry-Burrell has received ISO 9001 certification.**



Metallurgical Control

Waukesha Cherry-Burrell's reputation for pump reliability under severe operating conditions is directly related to carefully controlled casting production and consistency of metallurgical properties. It is this control that assures castings of uniform analysis that will perform dependably under all operating conditions.

**ISO 9001
CERTIFIED**



SPX®

PROCESS EQUIPMENT

Your document:



SPX Process Equipment
611 Sugar Creek Road
Delavan, WI 53115

Phone: (262)728-1900 or (800)252-5200 Fax: (262)728-4904 or (800)252-5012

E-mail: wcb@spx.com

For more information about our worldwide locations, approvals, certifications, and local representatives, please visit www.spxpe.com.

SPX Corporation reserves the right to incorporate our latest design and material changes without notice or obligation.

Design features, materials of construction and dimensional data, as described in this bulletin, are provided for your information only and should not be relied upon unless confirmed in writing.

Issued: 04/2009 FH-1733

Copyright © 1999, 2009 SPX Corporation